



Machines

Tandem Rollers
AV 70-2 / 85-2 / 95-2 / 115-2

www.ammann-group.com



The Best – fit compactor on asphalt

Heavy tandem rollers with rigid frame and split drums put optimal energy into bitumen even in bright curves.

Ammann tandem rollers AV 70-2, AV 85-2, AV 95-2 and AV 115-2 excel in compacting asphalt mixtures, also suits to mixed soils, sand, gravel and stabilizations. The vibratory rollers cope with compacting of medium and larger areas in road construction (highway, road and airfield construction) and building construction (industrial areas etc.).

AV 70-2, AV 85-2, AV 95-2 and AV 115-2 are built on backbone frames enabling crab-steering up to 1293 (1340) mm both sides. Two split drums help to reach small turning radius without risk of disturbing the top layer. Driver can move along the entire cab to check drum edges and surface while seating & driving comfortably with both hands. The driver can choose out of 3 options of steering via a front drum, rear drum or with both of them simultaneously. The optimum effect of compaction is accomplished via two-stage vibration exciters.

Combi rollers AV 70-2 K, AV 85-2 K and AV 95-2 K join benefits of vibratory and rubber tyred rollers. The front vibratory drum enables the machine to achieve high level of compaction, while the rear rubber tyred axle homogenizes a compacted surface.



Sliding & rotating seat with integrated control instruments



Pneu tyred rear axle



Crab up to 1293 (1340) mm



Options

Edge Cutter & Compactor

Controlled from cab, two-piece compactor-wheel with sprinkling nozzles.



Chip Spreader

Stable flow of chips within entire compacting width. Possibility to be equipped with crumble shaft, vibrator and stand.



Thermometer

Infrared sensor inspects IR-rays of bitumen. Driver reads temperature displayed on the dashboard.
(no image)



ACE Ammann Compaction Expert incl. IR thermometer

System of intelligent compaction on principle of continuous changeable amplitude & frequency. Possibility to be equipped with digital printer.

Long term service life

- Resistant steer bearings of the joints
- Perfect hydraulic oil filtration
- Maintenance intervals between the quarter of the year and 2 years
- Reliable vibration exciter

Long working intervals

- Optimal water tanks capacity (capacity versus weight change) 710 (1300) l
- Fuel tank 160 (210) l

Finger Tip Steering – Master of Ergonomic Control Systems

Finger Tip Steering is unique way to optimize ergonomic position of all parts of drivers body during every operation. It helps to reach excellent view from operators cockpit towards front drum surface and both front / rear drum edges. Comfortable seat includes 2 integrated side boxes with controls. Right box hosts drive lever forward/ backward. Left side of the seat furnish mini steering wheel. Driver can choose among 3 control modes (front / rear / both of the drums). LCD display informs him about chosen steering mode & actual turning angles of front and rear drum.

Drive control

- Soft stop/start function
- Continuous speed selection
- Inter-wheel & inter-axle differential lock
- Three control modes (front / rear / both of the drums) with crab run available in all 3 modes
- LCD display informs about steering mode & angle, crab distance, drum(s) frequency, machine speed and engine rpm

Drums (Efficient compacting)

- Split drums for max maneuverability
- Preset frequencies and amplitudes for the most applied asphalt layers
- Asphalt undulation-free drums (owning extra Nijboer factor values)
- Reliable sprinkler system

Cab (Operators comfort)

- Spacious cab with two-side access
- The seat sliding within entire width of cab, swiveling in 170° range
- All major controllers are positioned directly on the operators seat or nearby
- Excellent view from operators cockpit towards drum surfaces and their edges, even at night



AV 70-2 / 85-2 / 95-2 / 115-2

Tandem Rollers



Benefits:

Operator stays in one simple best position while sliding within entire width of cab even while rotating the seat in 170° range. Driving becomes more precise along edges, while turning or using crab mode. Less fatigue, longer working ability in hi-quality level.



AV 70-2 / 85-2 / 95-2 / 115-2

Tandem Rollers



		AV 70-2	AV 70-2 K	AV 85-2
Operating weight (CECE)	kg	6900	6650	8629
Compacting width maximum	mm	2633	2583	2973
Drum offset	mm	1183	1133	1293
Weights				
Operating weight max.	kg	7260	7010	9024
Front drum load (CECE)	kg	3450	3200	4248
Rear drum load (CECE)	kg	3450	3450	4381
Front drum linear load	kg/cm	23.8	–	25.3
Rear drum linear load	kg/cm	23.8	23.8	26.1
Steering				
Steering angle (+-) deg	°	2*25	2*25	2*25
Oscillation angle (+-) deg	°	6	6	6
Turning radius inner (edge)	mm	2590	2590	2780
Turning radius outer (contour)	mm	4277	4277	4502
Transversal stability - straight deg	°	28	28	32
Riding characteristic				
Maximal speed	km/h	9	9	10
Gradeability without vibration	%	35	35	35
Gradeability with vibration	%	30	30	30
Brakes				
Operation		Hydrostatic	Hydrostatic	Hydrostatic
Parking		Multi disc	Multi disc	Multi disc
Emergency		Multi disc	Multi disc	Multi disc
Vibration				
Amplitudes	mm	0.66 / 0.3	0.66 / 0.3	0.66 / 0.26
Frequencies	Hz	35 / 50	35 / 50	42 / 50
Centrifugal forces	kN	44 / 46	44 / 46	88 / 49
Watering		Pressure	Pressure	Pressure
No. of pumps		2	2	2
Water filtration stages		3	3	2
Tanks				
Fuel	l	125	125	160
Water	l	600	600	710
Electroinstallation				
Voltage	V	12	12	12
Capacity of batteries	Ah	100	100	135
Engine				
Make		Cummins	Cummins	Cummins
Type		4BT3.3-C85	4BT3.3-C85	4BT3.3-C85
Rated power	kW	63	63	63
Standard		ISO 3046/1	ISO 3046/1	ISO 3046/1

Dimensions (mm)	A	D	G	H	H1	H2	L	T	W	W1	W2
AV 70-2 / AV 70-2 K	2800	1150	308	2900	2350	810	3950	15	1450	1590	70
AV 85-2 / AV 85-2 K	3060	1220	340	2950	2400	897	4270	17	1680	1867	70
AV 95-2 / AV 95-2 K	3060	1220	340	2950	2400	897	4270	17	1680	1867	70
AV 115-2 / AV 115-2 K	3060	1300	285	3096	2424	887	4360	17	1750	1965	70

Technical data is subject to change. Machines may be shown with options.



AV 85-2 K	AV 95-2	AV 95-2 K	AV 115-2	AV 115-2 K
7905	9485	8375	11 550	10 059
2923	2973	2923	3090	2920
1243	1293	1243	1340	1170

8370	9880	8770	12 350	10 859
4248	4670	4670	5760	5760
3705	4815	3705	5790	4299
25.3	27.8	27.8	32.9	32.9
	28.7		33.1	

2*25	2*25	2*25	2*25	2*25
6	6	6	6	6
2780	2780	2780	2745	2748
4502	4502	4502	4598	4598
32	32	32	32	32

9	10	9	12	11
35	35	35	40	40
30	30	30	35	35

Hydrostatic	Hydrostatic	Hydrostatic	Hydrostatic	Hydrostatic
Multi disc	Multi disc	Multi disc	Multi disc	Multi disc
Multi disc	Multi disc	Multi disc	Multi disc	Multi disc

0.66 / 0.26	0.66 / 0.26	0.66 / 0.26	0.66 / 0.30	0.66 / 0.30
42 / 50	42 / 50	42 / 50	42 / 50	42 / 50
88 / 49 Watering	88 / 49	88 / 49	106 / 70	106 / 70
Pressure	Pressure	Pressure	Pressure	Pressure
2	2	2	2	2
2	2	2	2	2

160	160	160	210	210
710	710	710	1300	1300

12	12	12	12	12
135	135	135	135	135

Cummins	Cummins	Cummins	Cummins	Cummins
4BT3.3-C85	4BT3.3-C85	4BT3.3-C85	QSB4.5-30-T-C110	QSB4.5-30-T-C110
63	63	63	82	82
ISO 3046/1	ISO 3046/1	ISO 3046/1	ISO 3046/1	ISO 3046/1

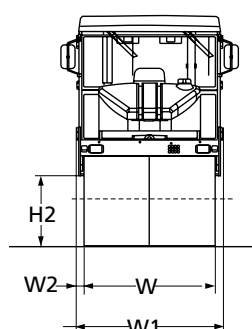
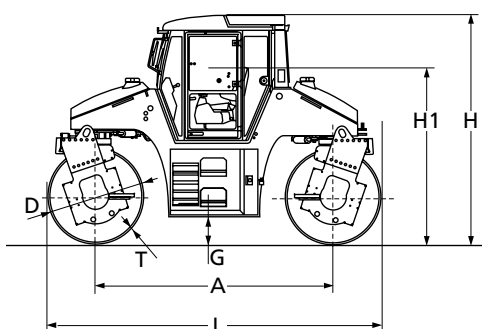

Standards

- CE conformity (incl. ROPS, noise red. kit, seat switch)
- Cab ventilated / heated
- Rotating / sliding seat with steering wheel / joy-stick
- Two drum vibration – two mode vibration
- Split drums
- Diff. lock ATC (interaxle and interdrum) – not combi versions
- Crab mode offset 1293 (1340) mm to both sides
- Quick release for brakes (hydr. Hand pump for emergency)
- Working halogen lights
- Cummins engine
- Standard painting
- Maintenance kit
- Electronically idle control (AV 115-2)

Options

- Open platform with ROPS and guarding rails, cover instrument panel
- Canvas canopy (mounted to ROPS)
- Air conditioning
- Radio w. antenna (Specify make and model)
- Rotating warning light
- Back-up alarm
- Additional headlights on cab 2+2
- Italo kit (back-up alarm, beacon, lic.plate)
- Electronically idle control (AV 85-2 / 95-2)
- Edge-cutter
- Edge-cutter both sides diagonal (AV 115-2)
- Chip spreader
- Infrared-Thermometer
- ACE Ammann Compaction Expert incl. IR Thermometer
- Fire extinguisher (Minimax)
- Toolkit
- Bio. degradable hydraulic oil (Panolin)

Ammann distribution
companies:

Switzerland:
Ammann Schweiz AG
CH-4901 Langenthal
Tel +41 62 916 61 61
Fax +41 62 916 65 40

Germany:
Ammann Verdichtung GmbH
D-53773 Hennef
Tel +49 22 42 880 20
Fax +49 22 42 880 259

Rammax Maschinenbau GmbH
D-72555 Metzingen
Tel +49 71 23 922 30
Fax +49 71 23 922 350

Czech Republic:
Ammann Czech Republic a.s.
CZ-54901 Nové Město nad Metují
Tel. +420 491 476 111
Fax +420 491 470 215

France:
Ammann France SA
F-94046 Créteil/Cedex
Tel +33 1 45 17 08 88
Fax +33 1 45 17 08 90

United Kingdom:
Ammann Equipment Ltd.
GB-Warwickshire, CV37 OTY
Tel +44 1789 414 525
Fax +44 1789 414 495

USA:
Ammann America Inc.
US-Ponte Vedra, Florida 32082
Tel +1 904 543 1691
Fax +1 904 543 1781

Ammann manufacturing
companies:

Switzerland:
Ammann Schweiz AG
CH-4901 Langenthal
Tel +41 62 916 61 61
Fax +41 62 916 64 03

Germany:
Ammann Verdichtung GmbH
D-53773 Hennef
Tel +49 22 42 880 20
Fax +49 22 42 880 259

Rammax Maschinenbau GmbH
D-72555 Metzingen
Tel +49 71 23 922 30
Fax +49 71 23 922 350

Czech Republic:
Ammann Czech Republic a.s.
CZ-54901 Nové Město nad Metují
Tel. +420 491 476 111
Fax +420 491 470 215

